

Overview



The SITRANS F M MAG 5100 W is an electromagnetic flow sensor designed to meet ground water, drinking water, waste water, sewage or sludge applications.

Benefits

- DN 15 to DN 1200 / 2000 (½" to 48"/78")
- Stock program of MAG 5100 W secures short delivery time
- Connection flanges EN 1092-1 (DIN 2501), ANSI, AWWA, AS and JIS.
- NBR Hard Rubber and Ebonite Hard Rubber liner for all water applications
- EPDM liner with drinking water approvals
- Hastelloy integrated grounding and measuring electrodes
- Increased low flow accuracy for water leak detection, due to coned liner design (Order No. 7ME6520, DN 15 to 300 mm (½" to 12")).
- Drinking water approvals
- Suitable for direct burial and constant flooding
- Custody transfer approvals
- Build-in length according to ISO 13359; the standard includes sizes up to DN 400.
- Easy commissioning, SENSORPROM unit automatically uploads calibration values and settings.
- Designed so patented in-situ verification can be conducted. Using SENSORPROM fingerprint.
- Custody Transfer option for water billing, with type approval after OIML R 49 and verified according to MI-001 for DN 50 (2") to DN 300 (12")
 - pattern approval OIML R 49 (Denmark, Germany)
 - conforms to ISO 4064 and EN 14154 for mechanical flowmeters
 - MI-001 Custody Transfer approval for billing (EU)
- Meets EEC directives: PED, 97/23/EC pressure directive for EN1092-1 flanges
- Simple onsite or factory upgrade to IP68/NEMA 6P of a standard sensor
- MCERTS approval for UK environmental market

Application

The main applications of the SITRANS F M electromagnetic flow sensors can be found in the following fields:

- Water abstraction
- Water treatment
- Water distribution network (leak detection management)
- Custody transfer water meters
- Irrigation
- Waste water treatment
- Filtration plant (e.g. reverse osmosis and ultra filtration)
- Industrial water applications

Mode of operation

The flow measuring principle is based on Faradays law of electromagnetic induction according to which the sensor converts the flow into an electrical voltage proportional to the velocity of the flow.

Integration

The complete flowmeter consists of a flow sensor and an associated transmitter SITRANS F M MAG 5000, MAG 6000 or MAG 6000 I.

The flexible communication concept USM II simplifies integration and update to a variety of fieldbus systems, e.g. HART, DeviceNet, PROFIBUS DP and PA, FOUNDATION Fieldbus H1, Modbus RTU/RS485.

Flow Measurement

SITRANS F M

Flow sensor MAG 5100 W

Technical specifications

Product characteristic	MAG 5100 W (7ME6520) Mainly for the European market EPDM or NBR lining	MAG 5100 W (7ME6580) Mainly for the non-European market Ebonite lining
Design and nominal size	Coned sensor: DN 15 ... 300 (½" ... 12") Full bore sensor: DN 350 ... 1200 (14" ... 48")	Full bore sensor: DN 25 ... 2000 (1" ... 78")
Measuring principle	Electromagnetic induction	Electromagnetic induction
Excitation frequency (Mains supply: 50/60 Hz)	DN 15 ... 65 (½" ... 2½"): 12.5 Hz/15 Hz DN 80 ... 150 (3" ... 6"): 6.25 Hz/7.5 Hz DN 200 ... 300 (8" ... 12"): 3.125 Hz/3.75 Hz DN 350 ... 1200 (14" ... 48"): 1.5625 Hz/1.875 Hz	DN 25 ... 65 (1" ... 2½"): 12.5 Hz/15 Hz DN 80 ... 150 (3" ... 6"): 6.25 Hz/7.5 Hz DN 200 ... 1200 (8" ... 48"): 3.125 Hz/3.75 Hz DN 1400 ... 2000 (54" ... 78"): 1.5625 Hz/1.875 Hz
Process connection		
Flanges		
<ul style="list-style-type: none"> EN 1092-1 	PN 10 (145 psi): DN 200 ... 300 (8" ... 12") Flat face PN 10 (145 psi): DN 350 ... 1200 (14" ... 48") Raised face ¹⁾ PN 16 (232 psi): DN 50 ... 300 (2" ... 12") Flat face ²⁾ PN 16 (232 psi): DN 350 ... 1200 (14" ... 48") Raised face PN 40 (580 psi): DN 15 ... 40 (½" ... 1½") Flat face	Raised face ²⁾ (EN 1092-1, DIN 2501 and BS 4504 have the same mating dimensions) PN 6 (87 psi): DN 1400 ... 2000 (54" ... 78") PN 10 (145 psi): DN 200 ... 2000 (8" ... 78") PN 16 (232 psi): DN 65 ... 600 (2½" ... 24") PN 40 (580 psi): DN 25 ... 50 (1" ... 2")
<ul style="list-style-type: none"> ANSI B16.5 	Class 150: ½" ... 12" flat face; 14" ... 24" raised face	Class 150: 1" ... 24"; raised face
<ul style="list-style-type: none"> AWWA C-207 	Class D: 28" ... 48", flat face	Class D: 28" ... 78", flat face
<ul style="list-style-type: none"> AS4087 	PN 16 (DN 50 ... 1200), (2" ... 48") 16 bar (232 psi)	PN 16 (DN 50 ... 1200), (2" ... 48") 16 bar (232 psi)
<ul style="list-style-type: none"> JIS B 2220:2004 	-	K10 (1" ... 24")
Rated Operation conditions		
Ambient temperature		
<ul style="list-style-type: none"> Sensor 	-40 ... +70 °C (-40 ... +158 °F)	-20 ... +70 °C (-4 ... +158 °F)
<ul style="list-style-type: none"> With compact transmitter MAG 5000/6000³⁾ 	-20 ... +60 °C (-4 ... +140 °F)	-20 ... +60 °C (-4 ... +140 °F)
Operating pressure (Abs) [abs. bar] (Maximum operating pressure depending on flange standard, decreases with increasing operating temperature)	DN 15 ... 40 (½" ... 1½"): 0.01 ... 40 bar (0.15 ... 580 psi) DN 50 ... 300 (2" ... 12"): 0.03 ... 20 bar (0.44 ... 290 psi) DN 350 ... 1200 (14" ... 48"): 0.01 ... 16 bar (0.15 ... 232 psi)	DN 25 ... 50 (1" ... 2"): 0.01 ... 40 bar (0.15 ... 580 psi) DN 65 ... 1200 (2½" ... 48"): 0.01 ... 16 bar (0.15 ... 232 psi) DN 1400 ... 2000 (54" ... 78"): 0.01 ... 10 bar (0.15 ... 145 psi)
Enclosure rating		
<ul style="list-style-type: none"> Standard 	IP67 to EN 60529/NEMA 4X/6 (1 mH ₂ O for 30 min)	IP67 to EN 60529/NEMA 4X/6 (1 mH ₂ O for 30 min)
<ul style="list-style-type: none"> Option 	IP68 to EN 60529/NEMA 6P (10 mH ₂ O continuously)	IP68 to EN 60529/NEMA 6P (10 mH ₂ O continuously)
Pressure drop	DN 15 and 25 (½" and 1"): Max. 20 mbar (0.29 psi) at 1 m/s (3 ft/s). DN 40 ... 300 (1½" ... 12"): Max 25 mbar (0.36 psi) at 3 m/s (10 ft/s) DN 350 ... 1200 (14" ... 48"): Insignificant	Insignificant
Test pressure	1.5 x PN (where applicable)	1.5 x PN (where applicable)
Mechanical load (vibration)	18 ... 1000 Hz random in x, y, z, directions for 2 hours according to EN 60068-2-36 Sensor: 3.17 grms Sensor with compact MAG 5000/6000 mounted transmitter: 3.17 grms Sensor with compact MAG 6000 I mounted transmitter: 1.14 grms	18 ... 1000 Hz random in x, y, z, directions for 2 hours according to EN 60068-2-36 Sensor: 3.17 grms Sensor with compact MAG 5000/6000 mounted transmitter: 3.17 grms Sensor with compact MAG 6000 I mounted transmitter: 1.14 grms

Product characteristic	Mainly for the European market (7ME6520)	Mainly for the non-European market (7ME6580)
	EPDM or NBR lining	Ebonite lining
<u>Medium conditions</u>		
Temperature of medium		
• NBR	-10 ... +70 °C (14 ... 158 °F)	-
• EPDM	-10 ... +70 °C (14 ... 158 °F)	-
• EPDM (MI-001)	0.1 ... 30 °C (32 ... 76 °F)	-
• Ebonite	-	-10 ... +70 °C (14 ... 158 °F)
EMC	2004/108/EC	2004/108/EC
Design		
Material		
• Housing and flanges	Carbon steel, with corrosion-resistant two-component epoxy coating (min. 150 µm) Corrosivity category C4, according to ISO 12944-2	Carbon steel ASTM A 105, with corrosion-resistant two-component epoxy coating (min. 150 µm) Corrosivity category C4, according to ISO 12944-2
• Measuring pipe	Stainless steel AISI 304/1.4301	Stainless steel AISI 304/1.4301
• Electrode	Hastelloy C	Hastelloy C
• Grounding electrode	Hastelloy C	Hastelloy C
• Terminal box	Fibre glass reinforced polyamide	Fibre glass reinforced polyamide
Certificates and approvals		
Calibration		
• Standard production calibration, calibration report shipped with sensor	Zero-point, 2 x 25 % and 2 x 90 %	Zero-point, 2 x 25 % and 2 x 90 %
Custody Transfer (only together with MAG 6000 CT)	OIML R 49 pattern approval cold water (Denmark and Germany): DN 50 ... 300 (2" ... 12") MI-001 cold water (EU): DN 50 ... 300 (2" ... 12") PTB K7.2: Chilled water energy metering DN 50-300 (order as special) Certificate number: 22 76.10 02	
Drinking water approvals	EPDM liner: NSF/ANSI Standard 61 (Cold water, US) WRAS (WRc, BS6920 cold water, GB) ACS (F) DVGW W270 (D) Belgaqua (B)	NSF/ANSI Standard 61 (Cold water, US) WRAS (WRc, BS6920 cold water, GB)
Other approvals	MCERTS PED conforming: All EN1092-1 flanges and ANSI Class 150 (< DN 300 (< 12")) – 97/23/EC ⁴⁾ CRN CSA Class I, Div 2 FM Class I, Div 2 VdS: Extinguishing systems DN 50 ... 300	PED conforming: All EN1092-1 flanges (≤ DN 600 (≤ 24") – 97/23/EC ⁴⁾ CRN CSA Class I, Div 2 FM Class I, Div 2

1) Type 01 (SORF)

2) DN ≤ 600 type 01 (SORF); DN > 600 type 11 (WNRF)

3) With compact transmitter MAG 5000 CT/6000 CT -20 ... +50 °C

4) For sizes larger than 600 mm (24") in PN 16 PED conformity is available as a cost-added option. The basic unit will carry the LVD (Low Voltage Directive) and EMC approval. All products sold outside of EU and EFTA are excluded from the directive, also products sold into certain market sectors are excluded. These include:

a) Meters used in networks for the supply, distribution and discharge of water.

b) Meters used in pipelines for the conveyance of any fluid from offshore to onshore.

c) Meters used in the extraction of petroleum or gas, including Christmas tree and manifold equipment.

d) Any meter mounted on a ship or mobile offshore platform. For further information on the PED standard and requirements see page 10/9.

Flow Measurement

SITRANS F M

Flow sensor MAG 5100 W

MAG 5100 W (7ME6520) with MAG 6000 CT (Revenue program) MI-001

MAG 5100 W CT program is type approved according to international water meter standard OIML R 49. Since the first November 2006 the MI-001 water meter directive is in force, which means that all water meters can be sold across the EU borders if the water meters contain a MI-001 label.

The MAG 5100 W MI-001 verified and labeled products are a Class II approval according to Directive 2004/22/EC of the European Parliament and Council of March 31, 2004 on measuring instruments (MID), Annex MI-001 in the sizes from DN 50 to DN 300 (Order No. 7ME6520).

The MID certification is obtained as a modul B + D module approval according to the above mentioned directive.

Module B : Type approval according to OIML R 49

Module D : Quality insurance approval of production

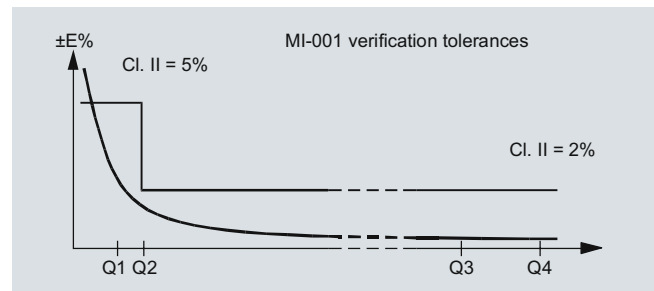

MAG 5100 W (7ME6520) MI-001 verified and labeled products at a given Q3 and Q3/Q4 = 1.25 and Q2/Q1 = 1.6 measuring ranges see table below:

Order code: P11	DN 50 (2")	DN 65 (2½")	DN 80 (3")	DN 100 (4")	DN 125 (5")	DN 150 (6")	DN 200 (8")	DN 250 (10")	DN 300 (12")
„R“ Q3/Q1	25	25	25	25	25	25	25	25	25
Q4 [m³/h]	20	31.25	50	78.75	125	200	312.5	500	787.5
Q3 [m³/h]	16	25	40	63	100	160	250	400	630
Q2 [m³/h]	1.02	1.6	2.6	4.03	6.4	10.24	16	25.6	40.32
Q1 [m³/h]	0.64	1.00	1.60	2.52	4.0	6.4	10.0	16.0	25.2

Order code: P12	DN 50 (2")	DN 65 (2½")	DN 80 (3")	DN 100 (4")	DN 125 (5")	DN 150 (6")	DN 200 (8")	DN 250 (10")	DN 300 (12")
„R“ Q3/Q1	63	63	63	63	63	63	63	63	63
Q4 [m³/h]	20	31.25	50	78.75	125	200	312.5	500	787.5
Q3 [m³/h]	16	25	40	63	100	160	250	400	630
Q2 [m³/h]	0.41	0.63	1.02	1.6	2.54	4.06	6.35	10.2	16.0
Q1 [m³/h]	0.25	0.40	0.63	1.00	1.59	2.54	3.97	6.35	10.0

Order code: P13	DN 50 (2")	DN 65 (2½")	DN 80 (3")	DN 100 (4")	DN 125 (5")	DN 150 (6")	DN 200 (8")	DN 250 (10")	DN 300 (12")
„R“ Q3/Q1	80	80	80	80	80	80	80	80	80
Q4 [m³/h]	20	31.25	50	78.75	125	200	312.5	500	787.5
Q3 [m³/h]	16	25	40	63	100	160	250	400	630
Q2 [m³/h]	0.32	0.50	0.80	1.20	2.00	3.20	5.0	8.0	12.6
Q1 [m³/h]	0.20	0.31	0.50	0.75	1.25	2.00	3.13	5.0	7.90

Order code: P16	DN 50 (2")	DN 65 (2½")	DN 80 (3")	DN 100 (4")	DN 125 (5")	DN 150 (6")	DN 200 (8")	DN 250 (10")	DN 300 (12")
„R“ Q3/Q1	160	160	160	160	160	160	160	160	160
Q4 [m³/h]	50	78.75	125	200	312.5	500	787.5	1250	2000
Q3 [m³/h]	40	63	100	160	250	400	630	1000	1600
Q2 [m³/h]	0.40	0.63	1.00	1.60	2.50	4.00	6.3	10.0	16.0
Q1 [m³/h]	0.25	0.39	0.63	1.00	1.56	2.50	3.94	6.3	10.0

Order code: P17	DN 50 (2")	DN 65 (2½")	DN 80 (3")	DN 100 (4")	DN 125 (5")	DN 150 (6")	DN 200 (8")	DN 250 (10")	DN 300 (12")
„R“ Q3/Q1	200	200	200	200	200	200	200	200	200
Q4 [m³/h]	50	78.75	125	200	312.5	500	787.5	1250	2000
Q3 [m³/h]	40	63	100	160	250	400	630	1000	1600
Q2 [m³/h]	0.32	0.50	0.80	1.28	2.00	3.20	5.0	8.0	12.8
Q1 [m³/h]	0.20	0.32	0.50	0.80	1.25	2.00	3.15	5.0	8.0

Order code: P18	DN 50 (2")	DN 65 (2½")	DN 80 (3")	DN 100 (4")	DN 125 (5")	DN 150 (6")	DN 200 (8")	DN 250 (10")	DN 300 (12")
„R“ Q3/Q1	250	250	250	250	250	250	250	250	250
Q4 [m³/h]	50	78.75	125	200	312.5	500	787.5	1250	2000
Q3 [m³/h]	40	63	100	160	250	400	630	1000	1600
Q2 [m³/h]	0.26	0.40	0.64	1.02	1.60	2.56	4.0	6.4	10.24
Q1 [m³/h]	0.16	0.25	0.40	0.64	1.00	1.60	2.52	4.0	6.4

The Label is placed on the side of the encapsulation. An example of the product label is shown below:



OIML R 49/MI-001 approvals valid for:

- DN 50 to 300 mm (2" to 12")
- Horizontal installation
- Compact or remote with max. 3 m cable
- Power supply 115/230 V AC

Other restrictions may apply (see certificate).

Special OIML / MI-001 settings:

- Unit: m³
- Qmax: Q3
- CutOff: 0.1 %
- Digital output: Frequency

For other factory settings, see Operating Instructions.

Flow Measurement

SITRANS F M

Flow sensor MAG 5100 W

Selection and Ordering data	Order No.
Sensor SITRANS F M MAG 5100 W	7 ME 6 5 2 0 -
Hastelloy electrodes, carbon steel flanges, EU water markets and low flow applications	■ ■ ■ 1 ■ - 2 ■ ■ ■ ■
Diameter	
DN 15 (½")	◆ 1 V
DN 25 (1")	◆ 2 D
DN 40 (1½")	◆ 2 R
DN 50 (2")	◆ 2 Y
DN 65 (2½")	◆ 3 F
DN 80 (3")	◆ 3 M
DN 100 (4")	◆ 3 T
DN 125 (5")	◆ 4 B
DN 150 (6")	◆ 4 H
DN 200 (8")	◆ 4 P
DN 250 (10")	◆ 4 V
DN 300 (12")	◆ 5 D
DN 350 (14")	◆ 5 K
DN 400 (16")	◆ 5 R
DN 450 (18")	◆ 5 Y
DN 500 (20")	◆ 6 F
DN 600 (24")	◆ 6 P
DN 700 (28")	◆ 6 Y
DN 750 (30")	7 D
DN 800 (32")	7 H
DN 900 (36")	7 M
DN 1000 (40")	7 R
(42")	7 U
(44")	7 V
DN 1200 (48")	8 B
Flange norm and pressure rating	
<u>to EN 1092-1</u>	
PN 10 (DN 200 ... 1200/8" ... 48")	◆ B
PN 16 (DN 50 ... 1200/2" ... 48")	◆ C
PN 16, non PED (DN 700 ... 1200/28" ... 48")	◆ D
PN 40 (DN 15 ... 40/½" ... 1½")	◆ F
<u>to ANSI B16.5</u>	
class 150 (½" ... 24")	◆ J
<u>to AWWA C-207</u>	
Class D (28" ... 48")	L
<u>to AS 4087</u>	
PN 16 (DN 50 ... 1200/2" ... 48")	N
Liner material	
EPDM	◆ 2
NBR Hard Rubber	◆ 3
Transmitter	
Sensor for remote transmitter (Order transmitter separately)	◆ A
MAG 6000 I, Aluminum, 18 ... 90 V DC, 115 ... 230 V AC	◆ C
MAG 6000, Polyamid, 11 ... 30 V DC/11 ... 24V AC	◆ H
MAG 6000, Polyamid, 115 ... 230 V AC	◆ J
MAG 5000, Polyamid, 11 ... 30 V DC/11 ... 24V AC	◆ K
MAG 5000, Polyamid, 115 ... 230 V AC	◆ L
MAG 6000 CT, Polyamid, 115 ... 230 V AC	◆ M

Selection and Ordering data	Order No.
Sensor SITRANS F M MAG 5100 W	7 ME 6 5 2 0 -
Hastelloy electrodes, carbon steel flanges, EU water markets and low flow applications	■ ■ ■ 1 ■ - 2 ■ ■ ■ ■
Communication	
None	◆ A
HART	◆ B
PROFIBUS PA Profile 3 (only MAG 6000/MAG 6000 I)	◆ F
PROFIBUS DP Profile 3 (only MAG 6000/MAG 6000 I)	◆ G
Modbus RTU/RS 485 (only MAG 6000/MAG 6000 I)	◆ E
FOUNDATION Fieldbus H1 (only MAG 6000/MAG 6000 I)	◆ J
Cable glands/terminal box	
Metric/Polyamid terminal box or 6000 I compact	◆ 1
½" NPT/Polyamid terminal box or 6000 I compact	◆ 2
◆ Short lead time (details in PMD)	

4

Flow Measurement

SITRANS F M

Flow sensor MAG 5100 W

Selection and Ordering data	Order code
Additional information	
Please add “-Z” to Order No. and specify Order code(s) and plain text.	
Factory certificate according to EN 10204-2.2	C14
Factory certificate according to EN 10204-2.1	C15
Approval/Verification ²⁾ (MI-001 : DN 50-300 compact, EPDM liner, EN 1092-1 PN10 and PN16 flanges with MAG 6000 CT) ³⁾	
• Without verification according to OIML R 49	P10
• MI-001 Q3/Q1 = 25	P11
• MI-001 Q3/Q1 = 63	P12
• MI-001 Q3/Q1 = 80	P13
• MI-001 Q3/Q1 = 160	P16
• MI-001 Q3/Q1 = 200	P17
• MI-001 Q3/Q1 = 250	P18
Tag name plate, stainless steel fixed with SS wire (add plain text)	Y17
Tag name plate, plastic (self-adhesive)	Y18
Customer-specific converter setup	Y20
Sensor cables wired (specify cable order no.)	Y40
Sensor for remote transmitter's junction box potted to IP68 with wired cable (specify cable order no.)	Y41
Other postproduction requirements (add desired text)	Y99
Additional Calibrations	
Matched pair - (Standard production calibration where sensor and transmitter are calibrated together)	On request¹⁾
Accredited Siemens Flow Instruments matched pair Calibration acc. to ISO/IEC 17025:2005	On request¹⁾
Customer-specified calibration up to 10 points	On request¹⁾
Customer-witnessed calibration Any of above calibration	On request¹⁾

- 1) Ordering On request as dedicated information from the customer on the individual sensors is required. Please fill in the calibration form found on pi.khe.siemens.de/index.aspx?Nr=17460 and send together with the order. (Size dependent restriction on maximum flow rates may apply)
- 2) For more details and references of the ranges please see the tables on page 4/73.
- 3) For remote version submit Product Variation Request.

Operating instructions for SITRANS F M MAG 5100 W

Description	Order No.
• English	A5E03063678
• German	A5E03376527
• Spanish	A5E00376529
• French	A5E03376521
• Chinese	A5E03376501

This device is shipped with a Quick Start guide and a CD containing further SITRANS F literature.

All literature is also available for free at:
<http://www.siemens.com/flowdocumentation>

Accessories

Description	Order No.
Potting kit for terminal box of SITRANS F M sensors for IP68/NEMA 6P (Not for Ex)	◆ FDK-085U0220



- ◆ Short lead time (details in PMD)

MAG 5000/6000 transmitters and sensors are packed in separate boxes, the final assembly takes place during installation at the customer's place. MAG 6000 I transmitters and sensors are delivered compact mounted from factory.

Communication module will be pre-mounted in the transmitter.

Please use online Product selector to get latest updates.

Product selector link:

www.pia-selector.automation.siemens.com

Please also see www.siemens.com/SITRANSFordering for practical examples of ordering

Flow Measurement

SITRANS F M

Flow sensor MAG 5100 W

Selection and Ordering data	Order No.
Sensor SITRANS F M MAG 5100 W	7 ME 6 5 8 0 -
Hastelloy electrodes, carbon steel flanges, Non EU water markets	■ ■ ■ ■ ■ - ■ ■ ■ ■ ■
Diameter	
DN 25 (1")	◆ 2 D
DN 40 (1½")	◆ 2 R
DN 50 (2")	◆ 2 Y
DN 65 (2½")	◆ 3 F
DN 80 (3")	◆ 3 M
DN 100 (4")	◆ 3 T
DN 125 (5")	◆ 4 B
DN 150 (6")	◆ 4 H
DN 200 (8")	◆ 4 P
DN 250 (10")	◆ 4 V
DN 300 (12")	◆ 5 D
DN 350 (14")	◆ 5 K
DN 400 (16")	◆ 5 R
DN 450 (18")	◆ 5 Y
DN 500 (20")	6 F
DN 600 (24")	6 P
DN 700 (28")	6 Y
DN 750 (30")	7 D
DN 800 (32")	7 H
DN 900 (36")	7 M
DN 1000 (40")	7 R
(42")	7 U
(44")	7 V
DN 1200 (48")	8 B
DN 1400 (54")	8 F
DN 1500 (60")	8 K
DN 1600 (66")	8 P
DN 1800 (72")	8 T
DN 2000 (78")	8 Y
Flange norm and pressure rating	
<u>to EN 1092-1</u>	
PN 6 (DN 1400 ... 2000 (54" ... 78"))	◆ A
PN 10 (DN 200 ... 2000 (8" ... 78"))	◆ B
PN 16 (DN 65 ... 600 (2½" ... 24"))	◆ C
PN 16, non-PED (DN 700 ... 2000 (28" ... 78"))	◆ D
PN 40 (DN 25 ... 50 (1" ... 2"))	◆ F
<u>to ANSI B16.5</u>	
class 150 (1" ... 24")	J
<u>to AWWA C-207</u>	
Class D (28" ... 78")	L
<u>to AS 4087</u>	
PN 16 (DN 50 ... 1200 (2" ... 48"))	N
<u>to JIS</u>	
B 2220:2004 K10 (1" ... 24")	R
Flange material	
Carbon steel flanges ASTM A 105	1
Liner material	
Ebonite Hard Rubber	4
Electrode material	
Hastelloy	2

Selection and Ordering data	Order No.
Sensor SITRANS F M MAG 5100 W	7 ME 6 5 8 0 -
Hastelloy electrodes, carbon steel flanges, Non EU water markets	■ ■ ■ ■ ■ - ■ ■ ■ ■ ■
Transmitter with display	
Sensor for remote transmitter (Order transmitter separately)	◆ A
MAG 6000, Polyamid, 11 ... 30 V DC/11 ... 24V AC	◆ H
MAG 6000, Polyamid, 115 ... 230 V AC	◆ J
MAG 5000, Polyamid, 11 ... 30 V DC/11 ... 24V AC	◆ K
MAG 5000, Polyamid, 115 ... 230 V AC	◆ L
Communication	
No communication, add-on possible	◆ A
HART	◆ B
PROFIBUS PA Profile 3 (only MAG 6000)	◆ F
PROFIBUS DP Profile 3 (only MAG 6000)	◆ G
Modbus RTU/RS 485 (only MAG 6000)	◆ E
FOUNDATION Fieldbus H1 (only MAG 6000)	◆ J
Cable glands/terminal box	
Metric	◆ 1
½" NPT	◆ 2

Selection and Ordering data	Order code
Additional information	
Please add "-Z" to Order No. and specify Order code(s) and plain text.	
Factory certificate according to EN 10204-2.2	C14
Factory certificate according to EN 10204-2.1	C15
Tag name plate, stainless steel fixed with SS wire	Y17
Tag name plate, plastic (self-adhesive)	Y18
Customer-specific converter setup	Y20
Sensor cables wired (specify cable order no.)	Y40
Sensor for remote transmitter's junction box potted to IP68 with wired cable (specify cable order no.)	Y41
Other postproduction requirements (add desired text)	Y99

Operating instructions for SITRANS F M MAG 5100 W

Description	Order No.
• German	A5E03376527
• English	A5E03063678
• French	A5E03376521
• Spanish	A5E03376529
• Chinese	A5E03376501

This device is shipped with a Quick Start guide and a CD containing further SITRANS F literature.

All literature is also available for free at:
<http://www.siemens.com/flowdocumentation>

Accessories

Description	Order No.
Potting kit for terminal box of SITRANS F M sensors for IP68/NEMA 6P (Not for Ex)	◆ FDK-085U0220



◆ Short lead time (details in PMD)

MAG 5000/6000 transmitters and sensors are packed in separate boxes, the final assembly takes place during installation at the customer's place.

Communication module will be pre-mounted in the transmitter.

Please use online Product selector to get latest updates.

Product selector link: www.pia-selector.automation.siemens.com

Please also see www.siemens.com/SITRANSOrdering

for practical examples of ordering

Dimensional drawings

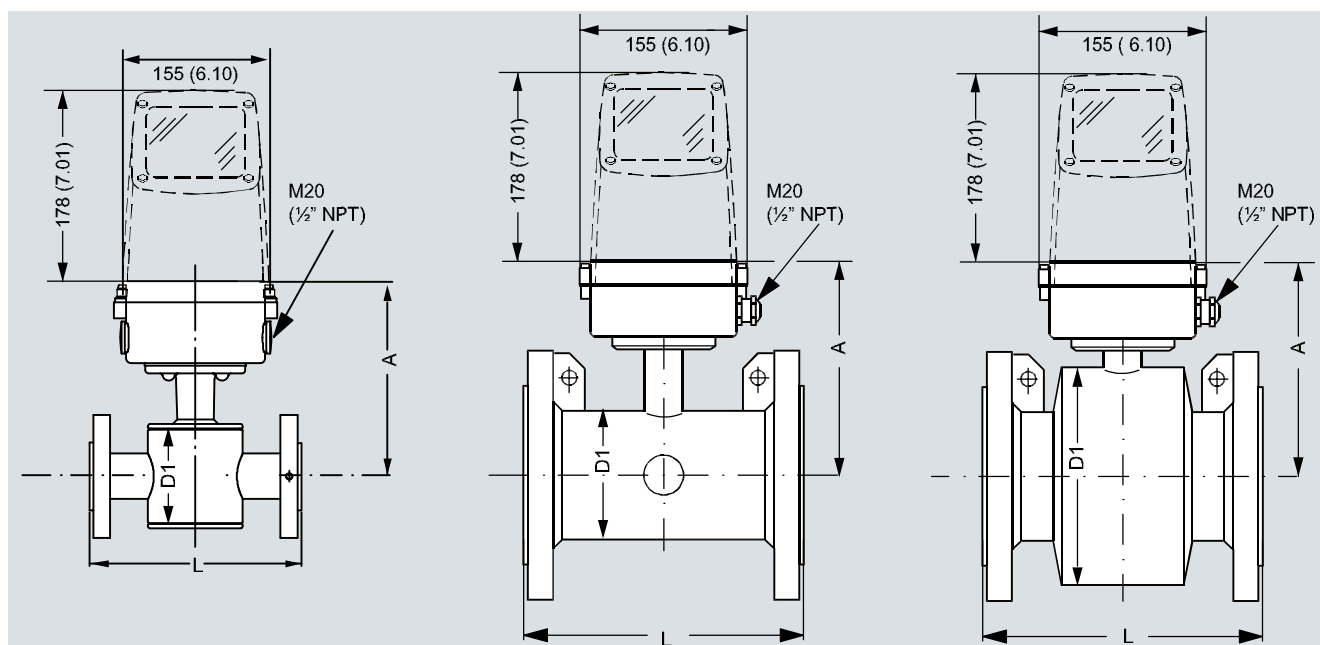

7ME6520 NBR or EPDM liner								7ME6580 Ebonite liner							
Nominal size	A	A1		D1		L		A	A1		D1		L		
[mm] [inch]	[mm] [inch]	[mm] [inch]	[mm] [inch]	[mm] [inch]	[mm] [inch]	[mm] [inch]	[mm] [inch]	[mm] [inch]	[mm] [inch]	[mm] [inch]	[mm] [inch]	[mm] [inch]	[mm] [inch]	[mm] [inch]	
15	1/2	177	7.0	331	13.0	77	3.0	-	-	341	13.4	104	4.09	200	7.9
25	1	187	7.4	341	13.4	96	3.8	187	7.4	351	13.8	104	4.09	200	7.9
40	1 1/2	202	8.0	356	14.0	127	5.0	197	7.8	359	14.1	124	4.88	200	7.9
50	2	188	7.4	342	13.5	76	3.0	205	8.1	366	14.4	139	5.47	200	7.9
65	2 1/2	194	7.6	348	13.7	89	3.5	212	8.3	376	14.8	154	6.06	200	7.9
80	3	200	7.9	354	14.0	102	4.0	222	8.7	396	15.6	174	6.85	200	7.9
100	4	207	8.1	361	14.2	114	4.5	242	9.5	409	16.1	214	8.43	250	9.8
125	5	217	8.5	371	14.6	140	5.5	255	10.0	430	16.9	239	9.41	250	9.8
150	6	232	9.1	386	15.2	168	6.6	276	10.9	458	18.0	282	11.1	300	11.8
200	8	257	10.1	411	16.2	219	8.6	304	12.0	486	19.1	338	13.31	350	13.8
250	10	284	11.2	438	17.2	273	10.8	332	13.1	511	20.1	393	15.47	450	17.7
300	12	310	12.2	464	18.3	324	12.8	357	14.1	516	20.3	444	17.76	500	19.7
350	14	382	15.0	536	21.1	451	17.8	362	14.3	541	21.3	502	19.76	550	21.7
400	16	407	16.0	561	22.1	502	19.8	387	15.2	572	22.5	563	22.16	600	23.6
450	18	438	17.2	592	23.3	563	22.2	418	16.5	597	23.5	614	24.17	600	23.6
500	20	463	18.2	617	24.3	614	24.2	443	17.4	648	25.5	715	28.15	600	23.6
600	24	514	20.2	668	26.3	715	28.2	494	19.4	698	27.5	816	32.13	600	23.6
700	28	564	22.2	718	28.3	816	32.1	544	21.4	725	28.5	869	34.21	700	27.6
750	30	591	23.3	745	29.3	869	34.2	571	22.5	760	29.9	927	36.5	750	29.5
800	32	616	24.3	770	30.3	927	36.5	606	23.9	807	31.8	1032	40.63	800	31.5
900	36	663	26.1	817	32.2	1032	40.6	653	25.7	858	33.8	1136	44.72	900	35.4
1000	40	714	28.1	868	34.2	1136	44.7	704	27.7	858	33.8	1136	44.72	1000	39.4
	42	714	28.1	868	34.2	1136	44.7	704	27.7	904	35.6	1238	48.74	1000	39.4
	44	765	30.1	919	36.2	1238	48.7	755	29.7	964	38.0	1348	53.07	1100	43.3
1200	48	820	32.3	974	38.3	1348	53.1	810	31.9	1079	42.5	1675	65.94	1200	47.2
1400	54	-	-	-	-	-	-	925	36.4	1126	44.3	1672	65.83	1400	55.1
1500	60	-	-	-	-	-	-	972	38.2	1179	46.4	1915	75.39	1500	59.1
1600	66	-	-	-	-	-	-	1025	40.4	1277	50.3	1974	77.72	1600	63.0
1800	72	-	-	-	-	-	-	1123	44.2	1377	54.2	2174	85.59	1800	70.9
2000	78	-	-	-	-	-	-	1223	48.1	-	-	-	-	2000	78.7

- not available

Flow Measurement SITRANS F M

Flow sensor MAG 5100 W

MAG 5100 W/6000 I Compact

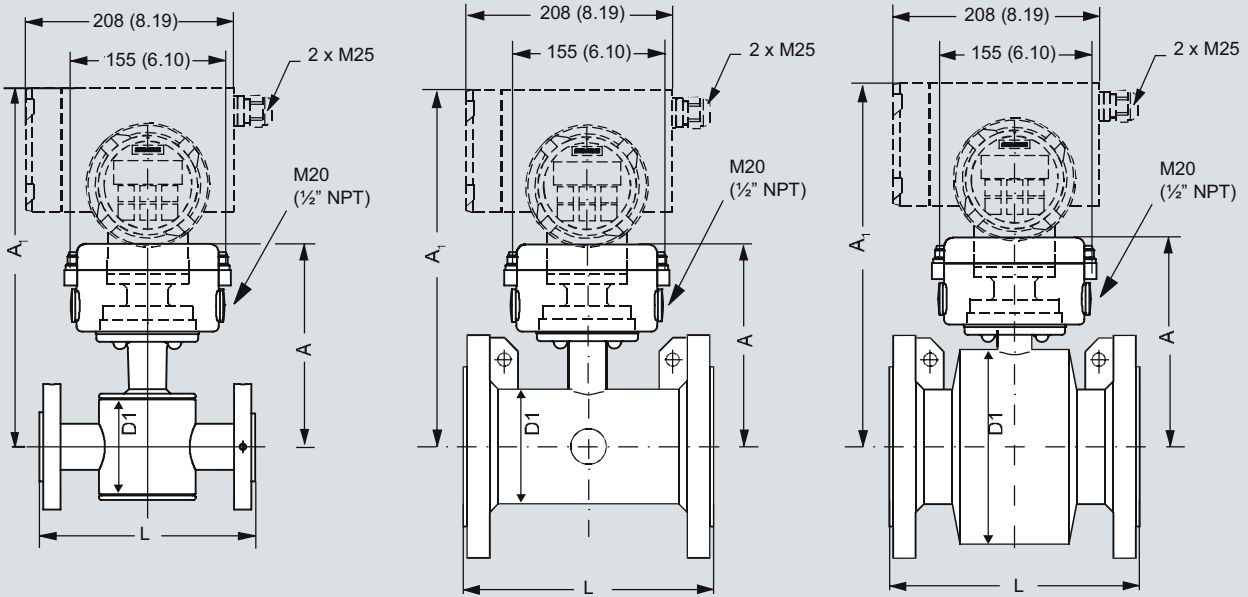

4

Nominal size	7ME6520 NBR or EPDM liner								7ME6580 Ebonite liner							
	A	A1		D1		A	A1		D1		L					
[mm] [inch]	[mm] [inch]	[mm] [inch]	[mm] [inch]	[mm] [inch]	[mm] [inch]	[mm] [inch]	[mm] [inch]	[mm] [inch]	[mm] [inch]	[mm] [inch]	[mm] [inch]	[mm] [inch]				
15	1/2	177	7.0	331	13.0	77	3.0	-	-	341	13.4	104	4.09	200	7.9	
25	1	187	7.4	341	13.4	96	3.8	187	7.4	351	13.8	104	4.09	200	7.9	
40	1 1/2	202	8.0	356	14.0	127	5.0	197	7.8	359	14.1	124	4.88	200	7.9	
50	2	188	7.4	342	13.5	76	3.0	205	8.1	366	14.4	139	5.47	200	7.9	
65	2 1/2	194	7.6	348	13.7	89	3.5	212	8.3	376	14.8	154	6.06	200	7.9	
80	3	200	7.9	354	14.0	102	4.0	222	8.7	396	15.6	174	6.85	200	7.9	
100	4	207	8.1	361	14.2	114	4.5	242	9.5	409	16.1	214	8.43	250	9.8	
125	5	217	8.5	371	14.6	140	5.5	255	10.0	430	16.9	239	9.41	250	9.8	
150	6	232	9.1	386	15.2	168	6.6	276	10.9	458	18.0	282	11.1	300	11.8	
200	8	257	10.1	411	16.2	219	8.6	304	12.0	486	19.1	338	13.31	350	13.8	
250	10	284	11.2	438	17.2	273	10.8	332	13.1	511	20.1	393	15.47	450	17.7	
300	12	310	12.2	464	18.3	324	12.8	357	14.1	516	20.3	444	17.76	500	19.7	
350	14	382	15.0	536	21.1	451	17.8	362	14.3	541	21.3	502	19.76	550	21.7	
400	16	407	16.0	561	22.1	502	19.8	387	15.2	572	22.5	563	22.16	600	23.6	
450	18	438	17.2	592	23.3	563	22.2	418	16.5	597	23.5	614	24.17	600	23.6	
500	20	463	18.2	617	24.3	614	24.2	443	17.4	648	25.5	715	28.15	600	23.6	
600	24	514	20.2	668	26.3	715	28.2	494	19.4	698	27.5	816	32.13	600	23.6	
700	28	564	22.2	718	28.3	816	32.1	544	21.4	725	28.5	869	34.21	700	27.6	
750	30	591	23.3	745	29.3	869	34.2	571	22.5	760	29.9	927	36.5	750	29.5	
800	32	616	24.3	770	30.3	927	36.5	606	23.9	807	31.8	1032	40.63	800	31.5	
900	36	663	26.1	817	32.2	1032	40.6	653	25.7	858	33.8	1136	44.72	900	35.4	
1000	40	714	28.1	868	34.2	1136	44.7	704	27.7	858	33.8	1136	44.72	1000	39.4	
	42	714	28.1	868	34.2	1136	44.7	704	27.7	904	35.6	1238	48.74	1000	39.4	
	44	765	30.1	919	36.2	1238	48.7	755	29.7	964	38.0	1348	53.07	1100	43.3	
1200	48	820	32.3	974	38.3	1348	53.1	810	31.9	1079	42.5	1675	65.94	1200	47.2	
1400	54	-	-	-	-	-	-	925	36.4	1126	44.3	1672	65.83	1400	55.1	
1500	60	-	-	-	-	-	-	972	38.2	1179	46.4	1915	75.39	1500	59.1	
1600	66	-	-	-	-	-	-	1025	40.4	1277	50.3	1974	77.72	1600	63.0	
1800	72	-	-	-	-	-	-	1123	44.2	1377	54.2	2174	85.59	1800	70.9	
2000	78	-	-	-	-	-	-	1223	48.1	-	-	-	-	2000	78.7	

- not available

Weight

Nominal size		7ME6520 NBR or EPDM liner										7ME6580 Ebonite liner	
		PN 10		PN 16		PN 40		Class 150/AWWA		AS		PN 16	
[mm]	[inch]	[kg]	[lbs]	[kg]	[lbs]	[kg]	[lbs]	[kg]	[lbs]	[kg]	[lbs]	[kg]	[lbs]
15	½	-	-	-	-	4	9	4	9	4	9	5	11
25	1	-	-	-	-	6	12	5	11	4	9	5	11
40	1½	-	-	-	-	8	18	7	15	7	15	8	17
50	2	-	-	9	20	-	-	8	20	9	20	9	20
65	2½	-	-	10.7	24	-	-	11	24	10.7	24	11	24
80	3	-	-	11.6	26	-	-	13	28	11.6	26	12	26
100	4	-	-	15.2	33	-	-	19	41	15.2	33	16	35
125	5	-	-	20.4	45	-	-	24	52	-	-	19	42
150	6	-	-	26	57	-	-	29	64	26	57	27	60
200	8	48	106	48	106	-	-	56	124	48	106	40	88
250	10	64	141	69	152	-	-	79	174	69	152	60	132
300	12	76	167	86	189	-	-	110	243	86	189	80	176
350	14	104	229	125	274	-	-	139	307	115	254	110	242
400	16	119	263	143	314	-	-	159	351	125	277	125	275
450	18	136	299	173	381	-	-	182	400	141	311	175	385
500	20	163	359	223	491	-	-	225	495	189	418	200	440
600	24	236	519	338	744	-	-	320	704	301	664	287	633
700	28	270	595	314	692	-	-	273	602	320	704	330	728
750	30	-	-	-	-	-	-	329	725	-	-	360	794
800	32	346	763	396	873	-	-	365	804	428	944	450	992
900	36	432	951	474	1043	-	-	495	1089	619	1362	530	1168
1000	40	513	1130	600	1321	-	-	583	1282	636	1399	660	1455
	42	-	-	-	-	-	-	687	1512	-	-	-	-
	44	-	-	-	-	-	-	763	1680	-	-	1140	2513
1200	48	643	1415	885	1948	-	-	861	1896	813	1789	1180	2601
1400	54	1592	3510	-	-	-	-	-	-	-	-	1600	3528
1500	60	-	-	-	-	-	-	-	-	-	-	2460	5423
1600	66	2110	4652	-	-	-	-	-	-	-	-	2525	5566
1800	72	2560	5644	-	-	-	-	-	-	-	-	2930	6460
2000	78	3640	8025	-	-	-	-	-	-	-	-	3665	8080

- not available

With transmitter MAG 5000 and MAG 6000 compact, weight is increased by approximately 0.8 kg (1.8 lbs), with MAG 6000 I, weight is increased by 5.5 kg (12.1 lb).